

# CARMIX 5.5 Extra Large

-  **MIXING UNIT:** Drum Capacity 7.600 liters. Concrete output: 5,5 m3 per batch. Double mixing screws, cover for emergency unloading. Drum rotation by hydraulic motor and planetary reducers. Mixing and discharging speed independent from r.p.m. of diesel engine. Discharging by reversing drum.
-  **ENGINE:** Cummins Turbo-Diesel B5.9 TAA, water-cooled, 6 cylinders. Maximum power 112 kW. (150 HP). Engine mounted transversal on the rear.
-  **TRANSMISSION:** Hydrostatic Bosch-Rexroth, Pump and motor are connected to the differentials through a 2 speed reducer (working and transfer), 4 wheel driving and steering.
-  **SPEED:** Working speed from 0 to 10 km/h, road transfer from 0 to 30 km/h.
-  **DRIVING SEAT:** Front cab on side of loading shovel. ROPS-FOPS type complete with double closing door.
-  **CHASSIS:** Steel profile specially engineered for off-road operations.
-  **HYDRAULIC SYSTEM:** Three circuits. 2 variable outlet pumps for hydrostatic transmission and drum rotation. 2 gear pumps for services. Inlet and outlet filter. Heat exchanger water/oil-air type.
-  **JOYMIX:** All hydraulic functions of shovel controlled by a single – fully servo controlled Joystick level.
-  **LOADING SHOVEL:** Capacity 600 liters. Complete with hydraulic opening gate.
-  **CHUTE:** Hydraulic slewing and hydraulic tilting controlled by the cab.
-  **WEIGHING:** Electronic System. "Load Cells" acting on the drum, display and printer in the cab (on request).
-  **WATER SYSTEM:** Self-contained. Hydraulic driven water pump, water meter. High pressure water pump (90 bar) for washing (on request).
-  **GRADIENT:** Fully loaded 30%.
-  **BRAKES:** Oil bath disc brakes inside differential axles. Twin independent circuits. Negative hydraulic parking brake.
-  **TYRES:** Off road industrial type 18-19,5 PR 16.
-  **STEERING:** Hydrostatic. 4 wheel steering self-lining. Radius: internal mm.1800 - external mm.4000
-  **ELECTRIC SYSTEM:** 12 Volt. 120 Ah battery for electric starter and road lighting. Safety battery cut-off.
-  **TANKS:** Water: 2x600 liters. Diesel: 150 liters. Hydraulic oil: 120 liters.
-  **WEIGHT:** About Kg. 8800. Equally distributed on both axles.
-  **SAFETY:** Machine equipped with checking and block valves for maximum safety of the operator.
-  **CATALOGUES:** The machine is equipped with Use and Maintenance and Spare Parts Manuals according to CE regulations.

As result of our policy of continuously developing and improving our product range, all specifications may change without notice.



## CARMIX 5.5 XL Extra Large



Organizzazione con Sistema di Gestione certificato Company with Management System certified ISO 9001:2000

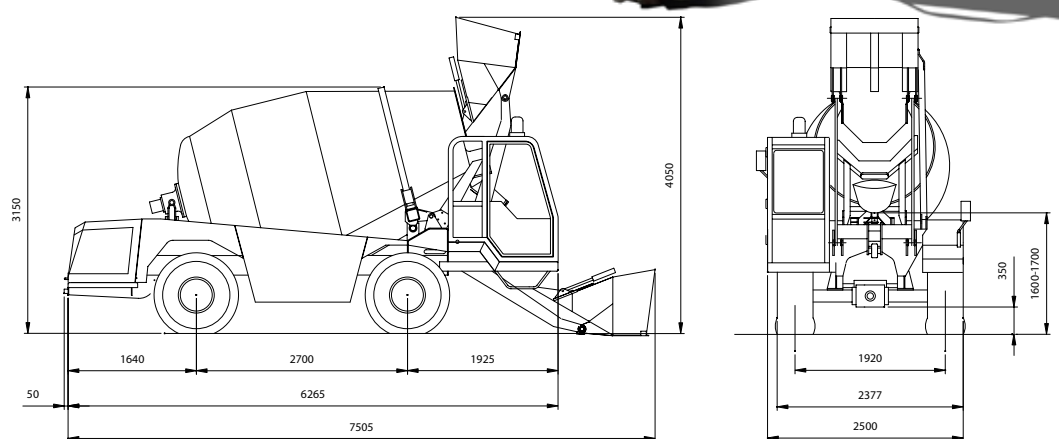

**Metalgalante**, the Company that invented and developed CARMIX, the No. 1 in the 4x4 Self-Loading Concrete Mixer. Thanks to 40 years of experience, CARMIX represents world-wide the Ideal Solution to produce high-quality cost-effective concrete wherever and whenever needed. From our Venice based factory, thousands of CARMIX have reached our Customers to over 130 Countries matching their utmost expectations.



30020 Noventa di Piave (Venice) Italy  
Tel. +39.042165191 - Fax +39.0421658838  
info@carmix.com  
Skype: carmix.main



## CARMIX 5.5 XL Extra Large

EASY & ECONOMIC CONCRETE ANYWHERE



carmix.com





# CARMIX 5.5 XL

## Extra Large



4 wheel driving all steering

### WHAT MAKES CARMIX THE N. 1

- Front driving cab to assure perfect visibility and excellent comfort to the operator.
- Self-Articulated hydraulically operating shovel for a more accurate loading of aggregates and cement.
- Discharging chute with hydraulic slewing and hydraulic tilting.
- High pressure washing pump (90 bar) for better cleaning (optional).
- Rear engine: easy checks. Fully balanced equipment.
- Oil-bath built-in disc brakes: no maintenance at all and total reliability.
- Rich fully equipped cockpit. Ergonomic Joymix; one joystick operates all main functions.
- Over 40 years of experience in the toughest jobsites.
- Electronic weighing system "Load Cell" acting on the drum to certify 100% quality of concrete, (on request).
- CARMIX selects the best suppliers in order to assure its customers not only with top quality but also their worldwide after-sale network. Among others we are proud to name CUMMINS engines, BOSCH-REXROTH transmissions, DANFOSS hydraulic motors, DANA SPICER axles,...



### JUST SUPPLY THE MATERIAL AND LET CARMIX...

#### LOAD:

Thanks to its unique articulated hydraulically operating shovel, CARMIX easily manages all the loading operations of the aggregates with perfect accuracy. The blade fitted inside the shovel permits the breaking of cement bags with no waste. From the shovel any material will flow smoothly and quickly into the drum (Electronic weighing system "Load cells" available on request).

#### MIX:

Once in the drum, aggregates and cement are perfectly mixed together with the self-pumped water from the twin tanks. Mixing quality and therefore concrete quality is granted by the double screw 4 mm tick. "T" type.

#### DELIVER:

No place is too difficult for CARMIX. The 4 wheel driving all steering hydrostatic transmission along with the ideal weight balance allow CARMIX to climb fully loaded over 30% gradients.

#### DISCHARGE:

The operator, acting the ergonomic JoyMix, pours concrete easily wherever required.

